

Proximity Detectors

Features

- 10mA Output Current
- Oscillator Frequency 10MHz
- Supply Voltage +4 to +35V

Description

These monolithic integrated circuits are designed for metallic body detection by sensing variations in high frequency Eddy current losses. Using an externally-tuned circuit, they act as oscillators. The output signal level is altered by an approaching metallic object.

The output signal is determined by supply current changes. Independent of supply voltage, this current is high or low, according to the presence or absence of a closely located metallic object.

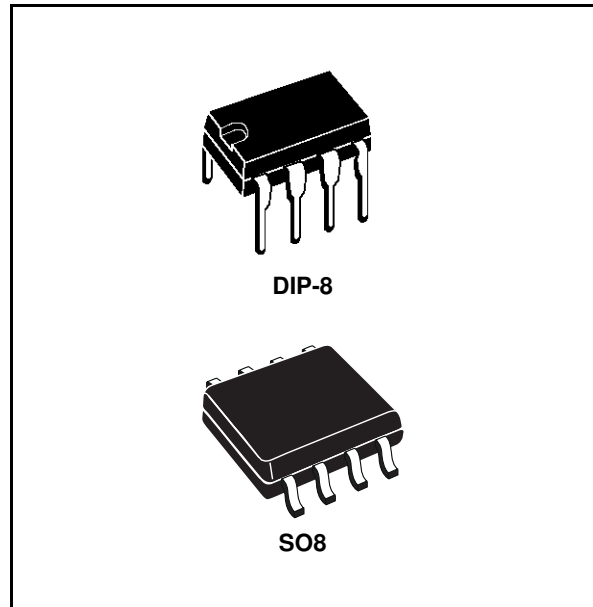

Block Diagram

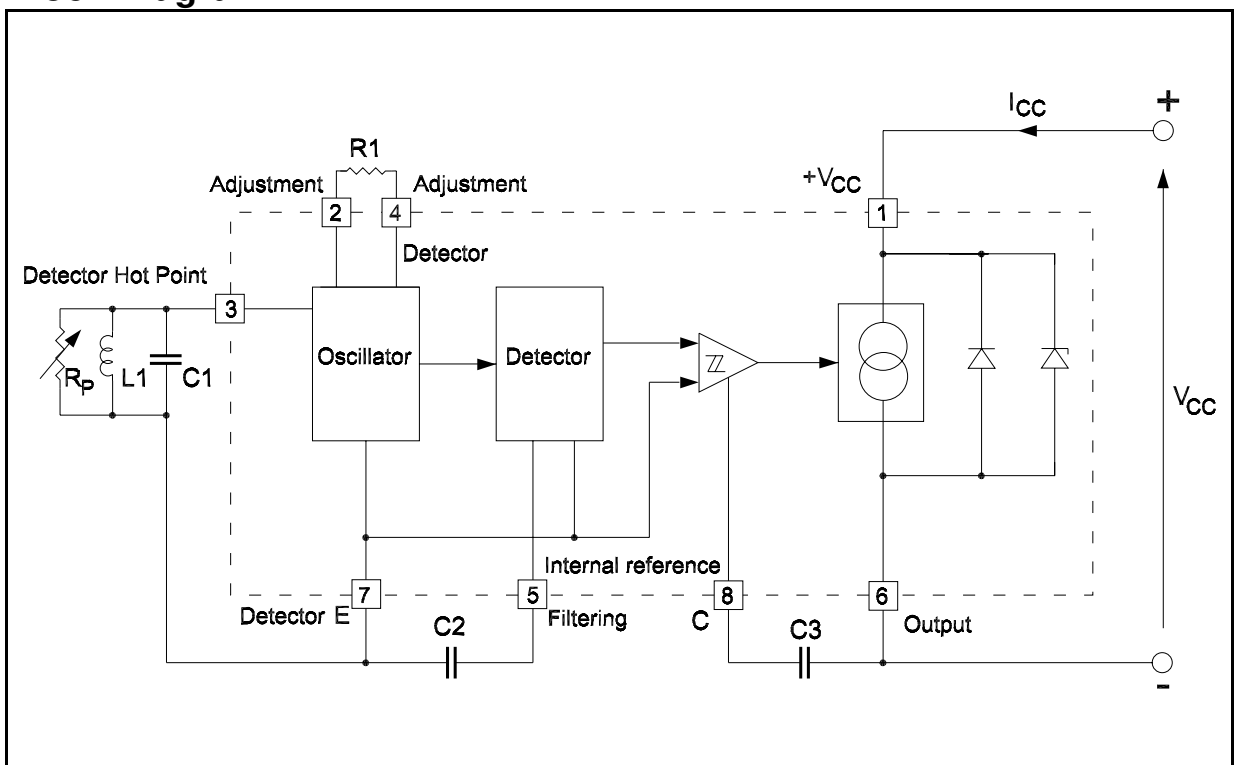

Contents

1	Connections	3
2	Electrical ratings	4
	2.1 Electrical characteristics	4
3	Operating Mode	5
4	Typical Applications	6
5	Package Mechanical Data	8
6	Order codes	10
7	Revision history	11

1 Connections

Figure 1. Pin Connections (top view)

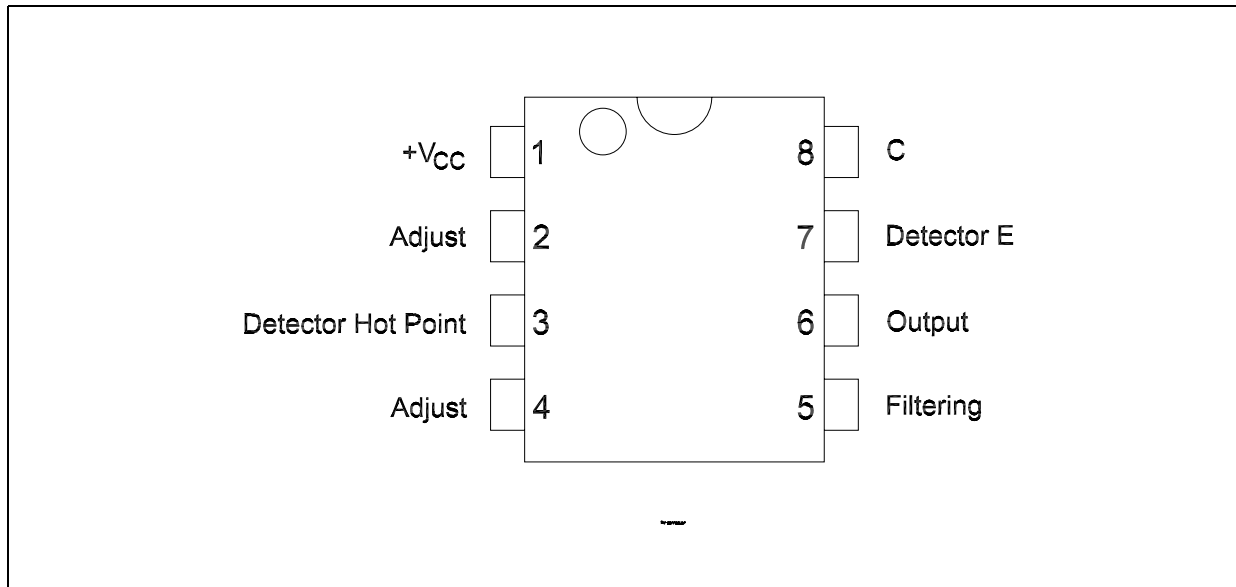

2 Electrical ratings

Table 1. Absolute maximum ratings

Symbol	Parameter	Value	Unit
V_{CC}	Supply Voltage	35	V
T_J	Operating Temperature Range	+150	°C
T_{STG}	Storage Temperature Range	-55 to 150	°C

2.1 Electrical characteristics

$-40 < T_A < +100^{\circ}\text{C}$, $P_{TOT} < 150\text{mW}$, unless otherwise specified.

Table 2. Electrical Characteristics

Symbol	Parameter	Test conditions	Min.	Typ.	Max.	Unit
V_{CC}	Supply Voltage		4		35	V
	Reverse Voltage Limitation	$I_{CC} = -100\text{mA}$		-1		V
I_{CC}	Supply Current close target	$T_A = +25^{\circ}\text{C}$ $+4\text{V} < V_{CC} < +35\text{V}$	8	10	12	mA
I_{CC}	Supply Current remote target	$+4\text{V} < V_{CC} < +35\text{V}$			1	mA
	Supply Current transition time	$C3 = 0$		1		μs
		$C3 \neq 0$		$100 \times C3$ (nF)		μs
f_{OSC}	Oscillator Tuning Frequency				10	MHz
f_O	Output Frequency	$C3 = 0$	0		10	kHz
ΔI_{CC}	Output Current Ripple	$C3 = 0$, $C2$ (pF) $> 150/f_{OSC}$ (MHz)			20	μA
R_n	Negative Resistance on Terminals A and E	$4\text{k}\Omega < R1 < 50\text{k}\Omega$, $f_{OSC} < 3\text{MHz}$	$0.9 R1$	$R1$	$1.1 R1$	
HYST	Hysteresis at Detection Point	$C2$ (pF) $> 150/f_{OSC}$ (MHz)	0.5		5	%

3 Operating Mode

Between pins 3 and 7, the integrated circuit acts like a negative resistor with a value equal to that of the external resistor R1 (connected between pins 2 and 4). The oscillation stops when the tuned circuit loss resistance (R_p) becomes smaller than R1. As a result, $I_{CC(close)} = 10\text{mA}$ (pins 1 and 6). The oscillation is sustained when R_p is higher than R1, and $I_{CC(remote)} = 1\text{mA}$ (pins 1 and 6). Eddy currents induced by coil L1 in a metallic body determine the value of R_p .

Figure 2. Electrical Scheme

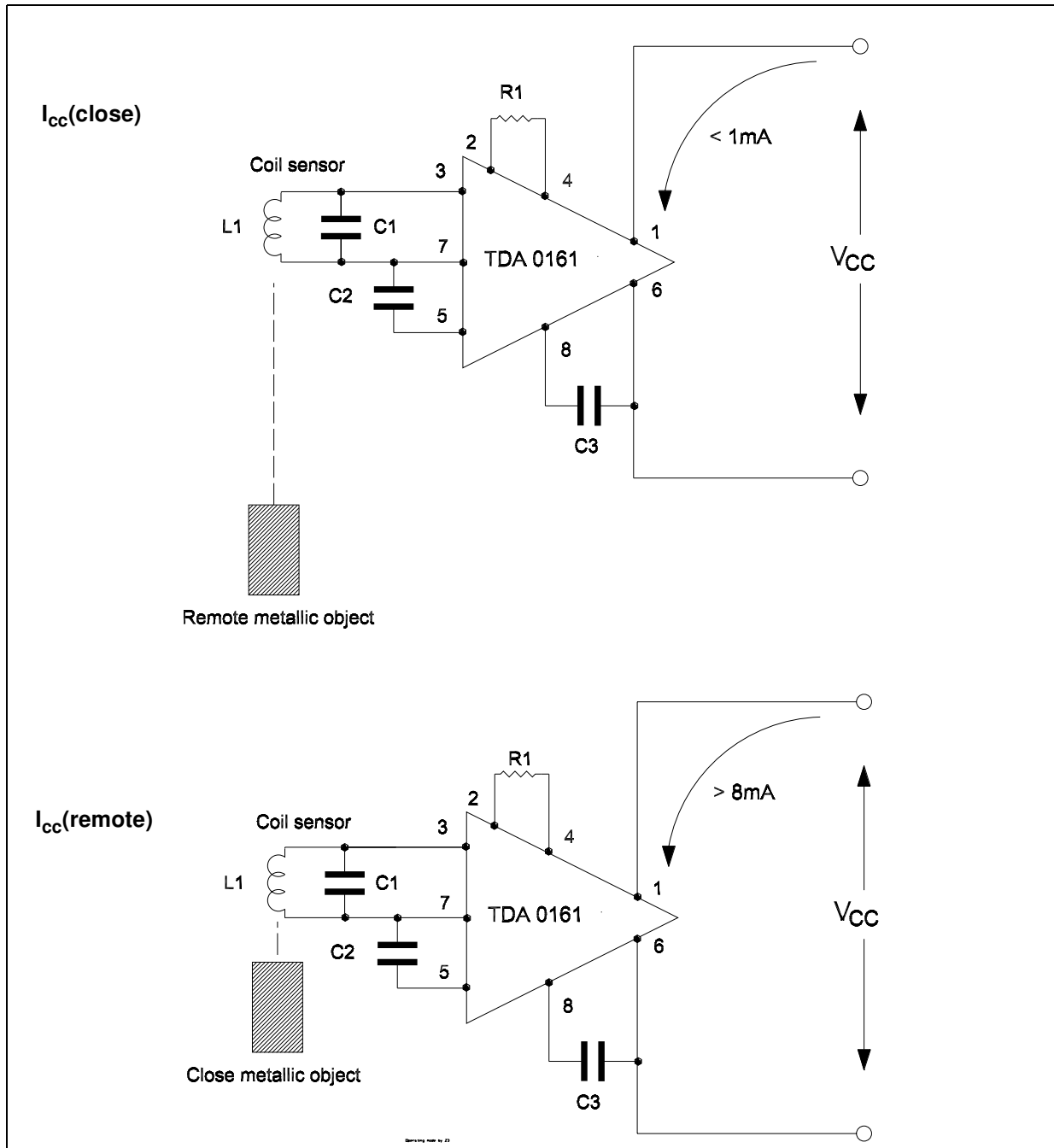

If the circuit is used at frequency higher than 3MHz, it is recommended to connect a capacitor of 100pF between pins 7 and 6

4 Typical Applications

Figure 3. Application Interface Connection Diagram

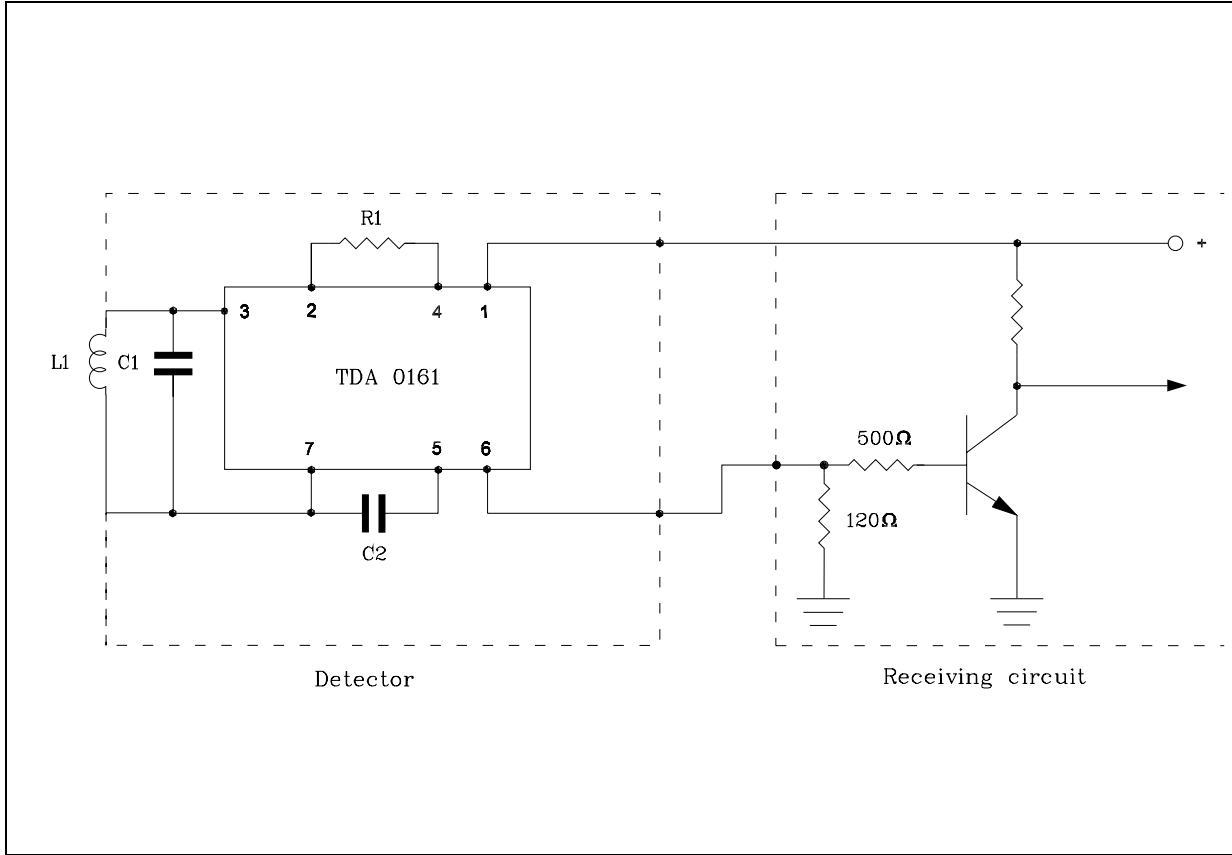

Table 3. Detection Range

Detection Range (#)	L1 (μH)	C1 (pF)	f _{OSC} (kHz)	R1 (kΩ)	C2 (pF)
2mm	30 (1)	120	2650	6.8	47
5mm	300 (2)	470	425	27	470
10mm	2160 (3)	4700	50	27	3300

Table 4. Coil Characteristics

	Core	Coil Former	Wire (##)	Number of Turns
1	Cofelec 432 FP 9 x 5 SE	1/2 Car 091 - 2	THOMSON Fils et Câbles Thomrex 14 (14 / 100mm)	40
2	Cofelec 432 FP 14 x 8 SE	1/2 Car 142 - 2		100
3	Cofelec 432 FP 26x 16 SE	1/2 Car 262 - 2		200

#) .Ingot steel target

##).The above results are obtained with single wire coil. When using Litz wire instead of single wire, the parallel resistance of the coil becomes higher and value of R1 may be increased, resulting in better sensitivity

4.1 Typical Application Example

Figure 4. Detection distance

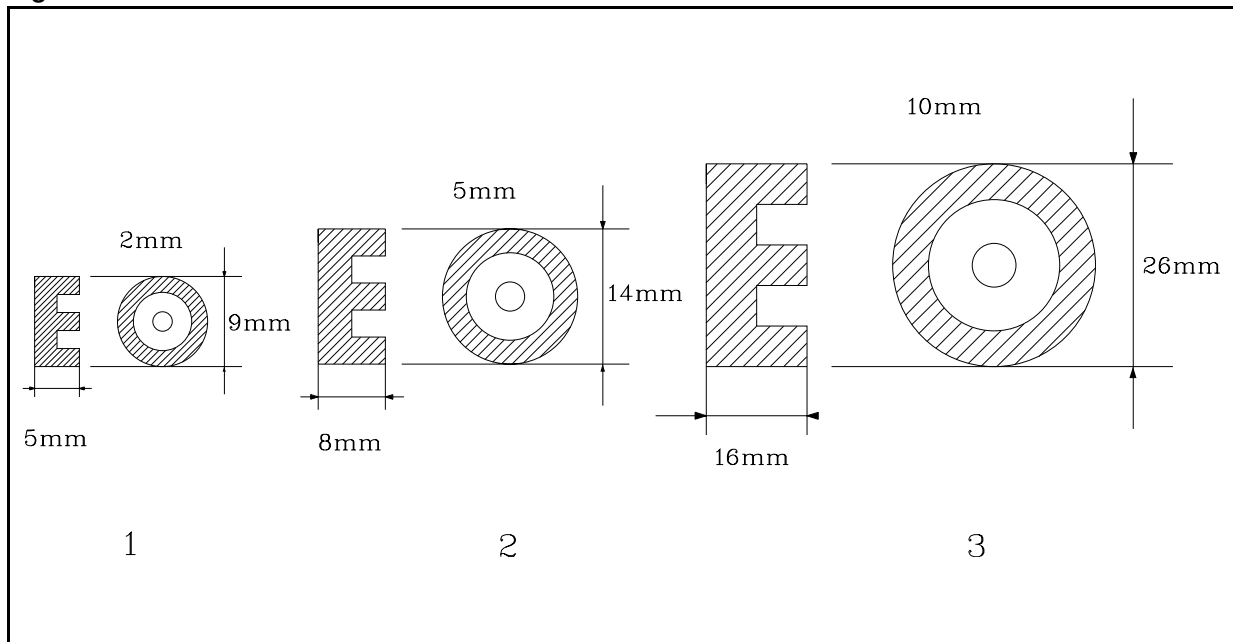

5 Package Mechanical Data

Plastic DIP-8 MECHANICAL DATA

DIM.	mm			inch		
	MIN.	TYP.	MAX.	MIN.	TYP.	MAX.
A		3.3			0.130	
a1	0.7			0.028		
B	1.39		1.65	0.055		0.065
B1	0.91		1.04	0.036		0.041
b		0.5			0.020	
b1	0.38		0.5	0.015		0.020
D			9.8			0.386
E		8.8			0.346	
e		2.54			0.100	
e3		7.62			0.300	
e4		7.62			0.300	
F			7.1			0.280
I			4.8			0.189
L		3.3			0.130	
Z	0.44		1.6	0.017		0.063

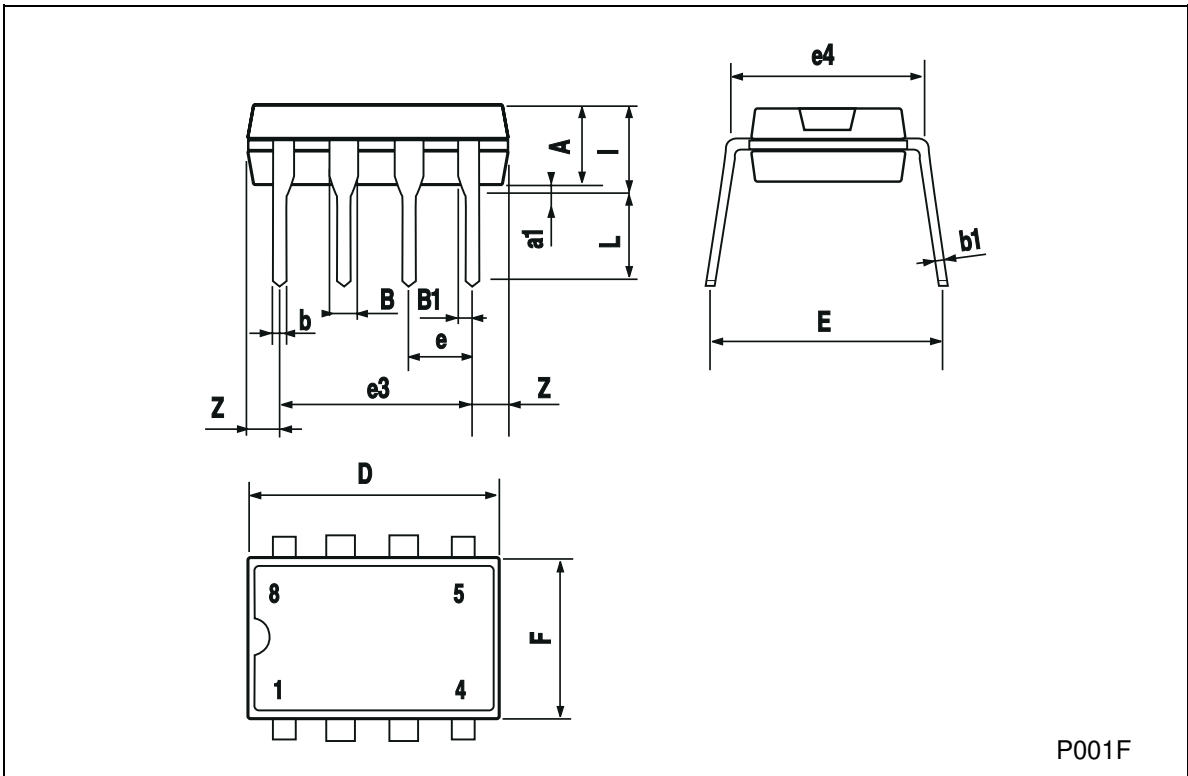

SO-8 MECHANICAL DATA

DIM.	mm.			inch		
	MIN.	TYP.	MAX.	MIN.	TYP.	MAX.
A			1.75			0.068
a1	0.1		0.25	0.003		0.009
a2			1.65			0.064
a3	0.65		0.85	0.025		0.033
b	0.35		0.48	0.013		0.018
b1	0.19		0.25	0.007		0.010
C	0.25		0.5	0.010		0.019
c1	45 (typ.)					
D	4.8		5.0	0.188		0.196
E	5.8		6.2	0.228		0.244
e		1.27			0.050	
e3		3.81			0.150	
F	3.8		4.0	0.14		0.157
L	0.4		1.27	0.015		0.050
M			0.6			0.023
S	8 (max.)					

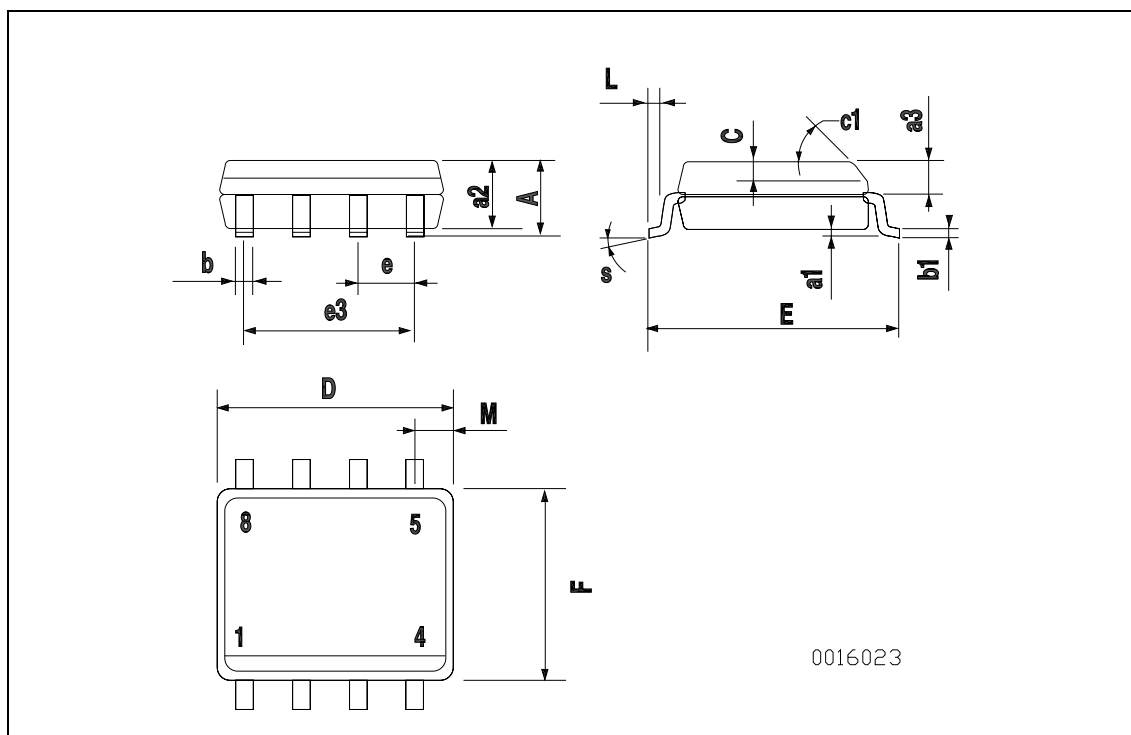

6 Order codes

Part number	Temp range	Package	Packing
TDA0161DP	150°C	DIP-8	Tube
TDA0161FP	150°C	SO8	Tube
TDA0161FPT	150°C	SO8	Tape and Reel

7 Revision history

Date	Revision	Changes
06-Jan-2003	1	Initial release.
12-Oct-2005	2	Final release.

Information furnished is believed to be accurate and reliable. However, STMicroelectronics assumes no responsibility for the consequences of use of such information nor for any infringement of patents or other rights of third parties which may result from its use. No license is granted by implication or otherwise under any patent or patent rights of STMicroelectronics. Specifications mentioned in this publication are subject to change without notice. This publication supersedes and replaces all information previously supplied. STMicroelectronics products are not authorized for use as critical components in life support devices or systems without express written approval of STMicroelectronics.

The ST logo is a registered trademark of STMicroelectronics.
All other names are the property of their respective owners

© 2005 STMicroelectronics - All rights reserved

STMicroelectronics group of companies

Australia - Belgium - Brazil - Canada - China - Czech Republic - Finland - France - Germany - Hong Kong - India - Israel - Italy - Japan -
Malaysia - Malta - Morocco - Singapore - Spain - Sweden - Switzerland - United Kingdom - United States of America

www.st.com